

EXPOSED THERMOSTATIC MIXER

A4917

A4817

A4717

A2917

General Warnings and notes

1. FOR USE WITH SHOWER HEADS RATED AT 2.5 GPM (9.5 L/min) OR HIGHER
2. The A4917 is supplied with a volume control for the top outlet. The thermostatic body kit and volume control kit are disassembled in the same packages. You must assemble both for a complete item.
3. The thermostatic body has secondary stops for servicing only. Do not leave the valve unattended during servicing. Do not leave the service stops in the off position with the thermostatic cartridge removed for any longer than servicing is necessary. No longer than 15 minutes.

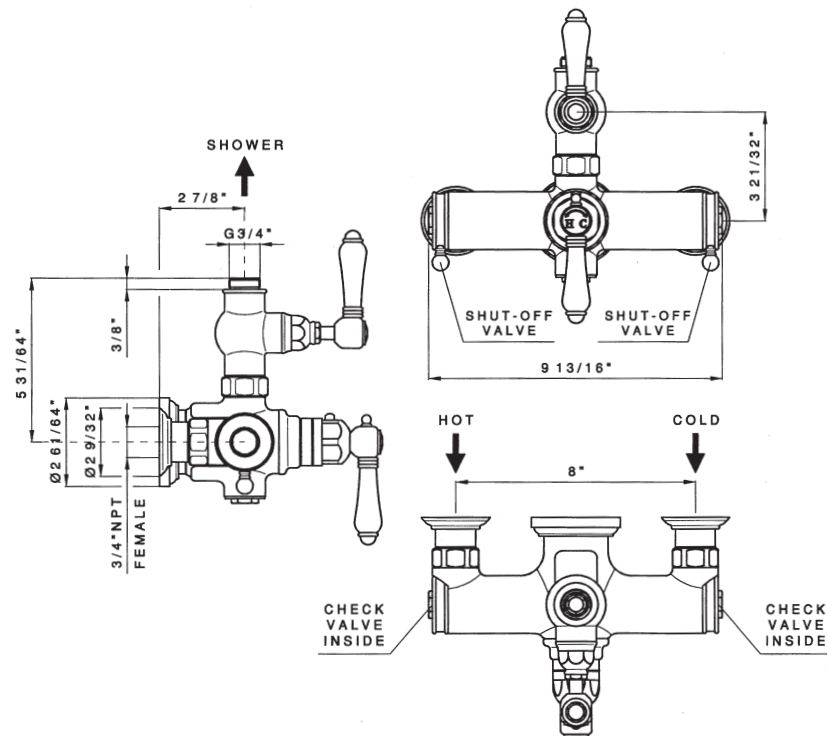

1. Hot will be on the left when viewed from the front. The volume control outlet are on the top. Warning: The valve is port specific. Cold must be on the cold port and hot must be on the hot port.
IMPORTANT: THE DISTANCE FROM CENTRE OF COLD WATER INLET TO CENTRE OF HOT WATER INLET MUST BE 8".
2. THE A4917 IS SUPPLIED WITH A VOLUME CONTROL FOR THE UPPER OUTLET ONLY. YOU MUST INSTALL THIS VOLUME CONTROL FOR THE UPPER OUTLET IN ALL INSTALLATION.
3. The mounting central holder should be utilized for stability
4. Do not move the thermostatic setting. There is a red dot on the thermostatic spindle that will line up with a dowel thread placed on the body. If this is moved, manually set the valve for 100 degrees Fahrenheit with the lever at 6 O'clock. Temperature cartridge is pre-set at the factory.
5. Sweat connections are not recommended. Heating the valve may damage the cartridge, screens or/and one-way valves.
6. Flush the valve after installation. Service stops are included in the rough to assist in flushing and servicing the rough. Do not leave the valve unattended during servicing. Do not leave the service stops in the off position with the thermostatic cartridge removed for any longer than servicing is necessary. No longer than 15 minutes.
7. When installing 2 thermostatic valves in one area, the hot water supply must be dedicated to each valve. Sharing the hot water supply may result in inconsistent hot water delivery.
8. If further building work is to be carried out in the vici of the faucet, it should be covered to prevent paint, adhesive, etc. from damaging the surface.
9. CHECK THE INSTALLATION CAREFULLY FOR LEAKS AFTER INSTALLATION.

TECHNICAL INFORMATION

RECOMMENDED HOT WATER SUPPLY FROM WATER HEATER: 140 F
MINIMUM: 118.4 F MAXIMUM: 185 F

RECOMMENDED PRESSURE REQUIREMENTS: 43 PSI
MINIMUM: 15 PSI MAXIMUM: 72 PSI

IMPORTANT: THE WATER PRESSURE ON THE HOT AND COLD SUPPLIES MUST BE THE SAME PRESSURE OR THE VALVE WILL NOT MIX HOT AND COLD WATER PROPERLY. MAXIMUM PRESSURE DIFFERENCE BETWEEN HOT AND COLD IS 15 PSI.

FLOW RATE: 16 GPM AT 40 PSI

FACTORY SETTING OF THERMOSTATIC CARTRIDGE: 100.4 F
CARTRIDGE CAN BE MANUALLY SET AFTER INSTALLATION ONLY IF NEEDED. SEE INSTALLATION INSTRUCTION SECTION.
ANY POSSIBLE MOVEMENT OF THE SPINDLE BEFORE INSTALLATION MAY CAUSE IMPROPER TEMPERATURE DELIVERY

CONNECTIONS: 3/4" NPT

THERE ARE PRIMARY SCREENS ON THE HOT AND COLD INLETS TO PROTECT THE CARTRIDGE FROM DEBRIS.

INSTALLATION

Note: The volume control is disassembled in the box. The loose parts are:

1. Wall connections kit C4917E.
2. Central holder (C4917/9+C1480/7) with sliding ring (C4917/10).
3. The volume control kit with O-Ring (C7586.77+C7586.64).

INSTALLATION:

1. Install the wall connections C4917E (1) with an allen key (not supplied) placing before the sliding caps C4912/4 (2).
2. Install the central holder C4917/9 (3) with a dowel kit C1480/7 (4).
IMPORTANT: Place it in the exact middle of the distance and in the same inlets fixing line (see the drawing beside).
3. Connect the thermostatic body (5) to the wall connections (1) having care to place the O-Ring between the two parts.
4. Slide the rings (2 and 6) to the wall.
5. Assemble the volume controle (7) to the thermostatic body (8) having care to place the O-Ring between the two parts.
6. Connect the external shower to the shower outlet (10) having care to place the O-Ring between the two parts.
7. Eusure all connections are firmly tightened.
8. Check hot and cold water pressure and temperature values (please see "technical information" section).
9. Turn on the water supply to the faucet and check the installation carefully for leaks.
10. Test the valve.

Please note: if you need a cartridge calibration in place of troubleshooting requirement please see the section "changing thermostatic control cartridge".

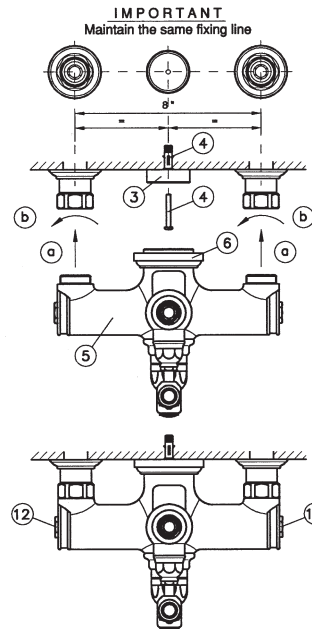
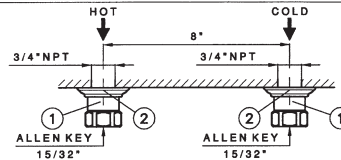

OPERATION OF VALVE

- ROTATING THE HANDLE (9A) COUNTER CLOCKWISE THE WATER WILL TURN ON AND TURN OFF IF CLOCKWISE.
- WITH THE HANDLE IN THE 6 O'CLOCK POSITION (9B), THE VALVE SHOULD RUN AT 100.4 F.
- PUSHING THE HOT LIMIT STOP (11) IN AND ROTATING THE HANDLE COUNTER CLOCKWISE, THE WATER WILL GET WARMER.
- MOVING THE HANDLE CLOCKWISE WILL PRODUCE COOLER WATER.

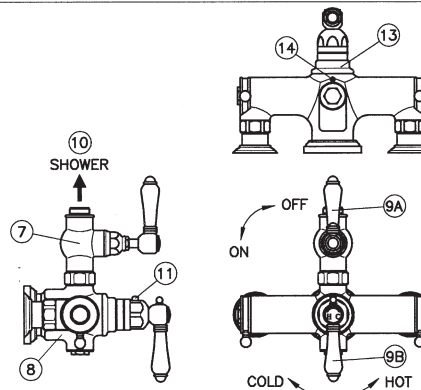

CARE AND MAINTENANCE

Manual cartridge setting

i. To change the factory temperature setting:

1. Set the volume control (9A) to off or 12 o'clock.
2. Place the lower thermostatic lever (9B) at 6 o'clock.
3. Remove the cartridge setting kit (13) by removing the dowel C7552 (14). Be careful to retain all parts.
4. Turn the volume control on to one of the functions.
5. With a thermometer, turn the cartridge stem (15) until you get the required degree Fahrenheit at the outlet.

Please note:

- a. turn counter clockwise to increase the temperature
 - b. turn clockwise to decrease the temperature
 - c. do not over twist the cartridge. There are internal stops that can be broken if it is turned beyond the stop.
6. Turn the water off.
 7. Reverse the steps to re-assemble.

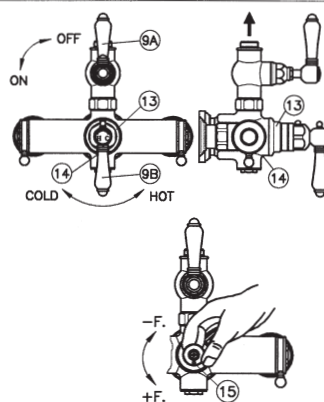

Cleaning the filtration system

i. To clean the filters if there is low flow or low temperature:

1. Set the volume control (9A) to off or 12 o'clock.
2. Place the lower thermostatic lever (9B) at 6 o'clock.
3. Turn the hot and cold supplies off: See "Using the service stops".
4. Remove the external hexagonal nut (12) to extract the filter.
5. Flush the filters.
6. Flush the lines to remove any debris.
7. Reverse the steps to re-assemble.

Changing the volume control cartridge

i. To change the volume control cartridge:

1. Set the volume control (9A) to off or 12 o'clock.
2. Place the lower thermostatic lever (9B) at 6 o'clock.
3. Turn the hot and cold supplies off: See "Using the service stops".
4. Remove the volume control cartridge.
5. Install the new volume control cartridge.
6. Reverse the steps to re-assemble.

Changing thermostatic control cartridge

i. To change the thermostatic control cartridge:

1. Set the volume control (9A) to off or 12 o'clock.
2. Place the lower thermostatic lever (9B) at 6 o'clock.
3. Remove the cartridge setting kit (13) by removing the dowel C7552 (14). Be careful to retain all parts.
4. Turn the hot and cold supplies off: See "Using the service stops".
5. Remove the thermostatic control cartridge.
6. Install the new thermostatic cartridge.
7. Turn the hot and cold supplies on: See "Using the service stops".
8. To calibrate the thermostatic cartridge:
 - a. With the cartridge setting kit (13) off, turn the volume control on to one of the functions.
 - b. With a thermometer, turn the cartridge control counter clockwise until you get 100.4 degrees Fahrenheit at the outlet. Do not over twist the cartridge. There are internal stops that can be broken if it is turned beyond the stop.
 - c. Turn the water off.
9. Reverse the steps to re-assemble.

CARE AND MAINTENANCE

Care and use for finishes

Country Bath Products are all authentic finishes that have not been coated with any product.

After each use, pat the fixture down to remove any excess water. This will prevent any water spotting or mineral build-up. Use only soft liquid soap and water to clean the surface. Use a soft brush to clean any gaps. Avoid any products that have ammonia or alcohol like Windex, 409 or Fantastik. These products can damage the finish leaving black or white spots. Never use an abrasive product like Softscrub, Comet, Ajax or Bon Ami.

For deep polishing we recommend Bruno's Wax for all finishings.

Tuscan Brass is a living finish and has no warranty. It will lighten with use. To extend the life of the finish, apply Bruno's Wax by patting it on, letting it dry and patting it off. Never rub or buff this finish.

SERVICING

Using the service stops

THE SHUT-OFF VALVE IS NOT A STOP COCK, BUT ONLY A VALVE THAT ALLOWS TEMPORARY SHUT-OFF FOR MAINTENANCE OPERATIONS LIKE FILTER CLEANING, FLUSHING THE VALVE AND CARTRIDGE REPLACEMENT

Do not leave the valve unattended during servicing. Do not leave the service stops in the off position with the thermostatic cartridge removed for any longer than servicing is necessary. No longer than 15 minutes.

When the valve is closed, you could notice a slight drip. This is normal. DO NOT ALLOW THE WATER TO COLLECT IN THE WALL CAVITY. FUNNEL THE WATER AWAY FROM THE INNER WALL CAVITY TO THE SHOWER STALL.

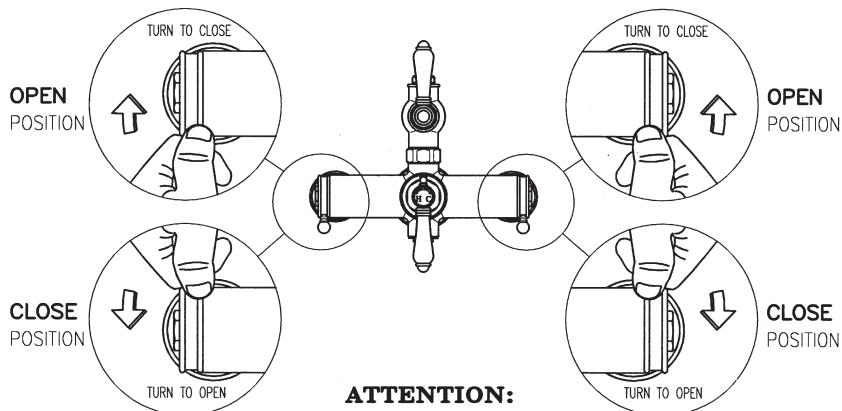

Stop is for temporary use only. Do not leave valve unattended when stop is in the off position. If leaking, rotate stop one full turn to lubricate the stop. A drip in the off position is common. Call 800.777.9762 if problem persists. Do not replace the valve. The stop valve can be replaced if the problem does not stop in the open position.

WARRANTY

Country Bath Collection has a limited lifetime warranty.

"Warranty Exclusion: This warranty is for normal domestic use only and excludes defect or injury caused by or resulting from misuse, abuse, neglect, accidental damage or improper installation". There is no warranty on the finish Tuscan Brass.

TROUBLESHOOTING

	INDICATION OF MALFUNCTION	CAUSE OR DIAGNOSIS	POSSIBLE REMEDIES	FURTHER ATTENTION	
1	The water does not get hot enough, but there is variation in temperature.	The pre-set temperature is too low. Verify with the face plate off, to test the cartridge, by rotating the stem counter clockwise all the way for the hottest setting.	Remove the cartridge setting kit and re-set the valve according to the instructions.	Don't automatically change the cartridge.	The cartridge setting was checked during installation
2	The water does not get cold enough, but there is variation in temperature.	The pre-set temperature could be too high. With standard setting, absolute cold is not possible.	Remove the cartridge setting kit and re-set the valve according to the instructions.	Don't automatically change the cartridge.	If you lower the setting to get colder water, you could get less hot water.
3	On the cold setting, there is hot water, and on the hot setting, there is cold water. There is no mix of hot and cold at all.	The lines could be reversed. <u>The plumber must make this decision.</u>	The valve is port specific. The hot supply must be on the left and cold on the right as you face the valve. Have the plumber verify by feeling the pipes, or removing the cartridge, that the water lines are reversed before switching the lines.	Switching the pipes can be expensive. The diagnosis must be done at the home.	
4	The water temperature does not change when the handle is moved.	The cartridge stem is not contacting the handle assembly.	2 possible things might have happened: 1. The brass adaptor C7919 may be damaged. 2. The cartridge might be faulty.	Don't automatically change the cartridge.	
5	After a period of time, the water gets cold. It starts out hot, but then goes cold.	You might be running out of hot water. Ask how long, in minutes, this takes to happen.	Thermostatic valves can run at 16 gallons per minute. Find out the water heater capacity and divide by length of the shower in minutes for a function i.e. 50 gallons capacity divided by u.5205 flow of 8 gpm= approx 6 minutes hot water	Don't automatically change the cartridge.	
6	The flow gradually decreases.	There could be debris in the line.	Clean the filters and flush the lines according to the instructions.	Don't automatically change the cartridge.	
7	The flow stops.	The built in safety feature is stopping flow immediately if there is a decrease in temperature.	1. The valve could be operating properly. 2. There could be complete blockage in one of the supply lines.	Don't automatically change the cartridge.	
8	There is no flow on start-up.	1. There could be complete blockage in one of the supply lines. 2. The non-return lines may not be opening.	1. Clean the filters and flush the lines according to the instructions. 2. Check the non-return lines are installed correctly.	Don't automatically change the cartridge.	
9	Noise in the valve	1. Debris is causing noise 2. Check the one way valves	1. Flush the system 2. Change the one way valve	The valve cannot make noise by itself. Changing the cartridge is the last option	
10	Inconsistent or low temperature delivery	1. On demand water heater cannot keep up with the demand of the valve. 2. The pressure difference from the water supply is more than 15 p.s.i. 3. If a well system, the pressure could be fluctuating.	Consult your plumber. A professional needs to diagnose the problem.		

Care and use for finishes

Country Bath Products are all authentic finishes that have not been coated with any product.

After each use, pat the fixture down to remove any excess water. This will prevent any water spotting or mineral build-up. Use only soft liquid soap and water to clean the surface. Use a soft brush to clean any gaps. Avoid any products that have ammonia or alcohol like Windex, 409 or Fantastik. These products can damage the finish leaving black or white spots. Never use an abrasive product like Softscrub, Comet, Ajax or Bon Ami.

For deep polishing we recommend Bruno's Wax for all finishings.

Tuscan Brass is a living finish and has no warranty. It will lighten with use. To extend the life of the finish, apply Bruno's Wax by patting it on, letting it dry and patting it off. Never rub or buff this finish.

WARNING: the use of cleaning products not recommended might irreparably harm the surfaces of the faucets which in such case are not covered by our warranty.

Limescale

The faucet is fitted with an aeration device in the Hot/Cold water outlet.

This may need occasional cleaning especially in hard water areas.

This is accomplished by unscrewing the outlet in a counter clockwise direction, dismantling and leaving the inner screen mesh immersed over night in vinegar or lemon juice.

Do not use chemical descaling liquids for this purpose.

ATTENTION

READ THESE INSTRUCTIONS BEFORE INSTALLATION AND USE OF ALL FAUCETS AND WALL VALVES

INSTALLATION and WARRANTY INSTRUCTIONS TECHNICAL INFORMATION

All flexible hoses are designed and manufactured for use with water in exposed locations only. **Do not expose** to household cleaners, chlorine, chloride, hydrochloric acid or other corrosive chemicals.

- All connections with threads M10x1 male must be hand tighten. **Do not over tighten. Over tightening may cause damage to the hose.**

All faucets washers and o-rings are designed and manufactured for use with water. **Do not expose** to household cleaners, chlorine, chloride, hydrochloric acid or other corrosive chemicals.

Faucets are designed for use with the temperatures and pressures listed below:

- minimum cold water supply 50 °F
- maximum hot water supply 145 °F
- minimum pressure 15 psi
- maximum pressure 75 psi
- maximum fixing torque value = 10 lbf.ft.
-

Please note: The recommended best pressure for best performance is between 40 psi and 60 psi. More pressure than 60 psi or less pressure than 40 psi may affect the diverting action in side spray faucets.

- Do not use any Rohl Country/ Nicolazzi faucet with sulphorous water.
- The minimum temperature for all faucets is 50 degrees F. Below 50 degrees F will void the warranty.
- When available, filter systems must be placed between hot and cold supply lines and the faucet. Improper use or non-use of filters may make diverting faucets with hand sprays perform poorly.
- Don't modify faucet and their components
- Use only original spare parts if there are replacements to be ordered.
- Installation must be made by authorized plumbers or installers. Improper installation or diagnosis of problems is not covered by the warranty.
- Yearly maintenance of cleaning and flushing is recommended.

Operation and use of any faucet or wall valve that do not conform to these technical instructions will void the warranty.